

# HIGH FLOW HYDRAULIC MOTOR DRIVEN OILCOOLER



## PRODUCT INFORMATION

- High Flows 50 - 500 GPM
- Two Separate Oilcoolers Mounted in Steel Frame
- Dependable Long-Life Hydraulic Driven Fan
- Competitive Pricing, Deliveries from Stock

## COOLER DIMENSIONS

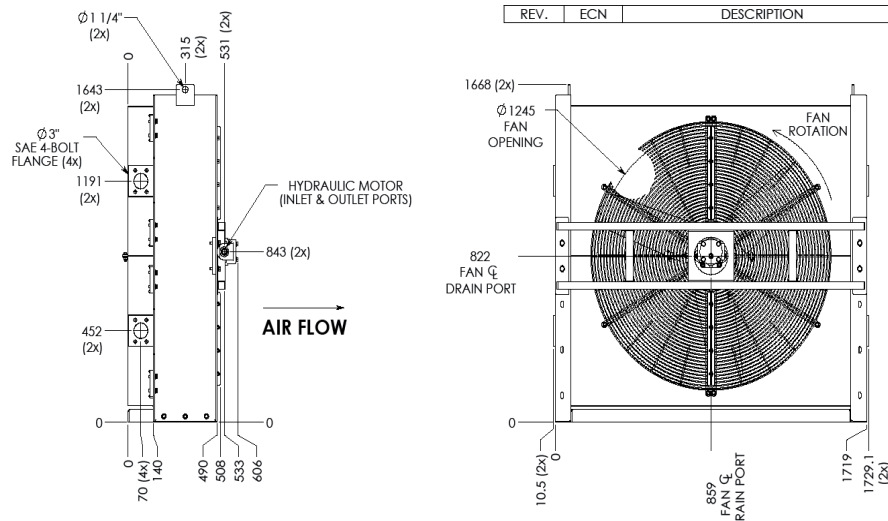

## TECHNICAL DATA

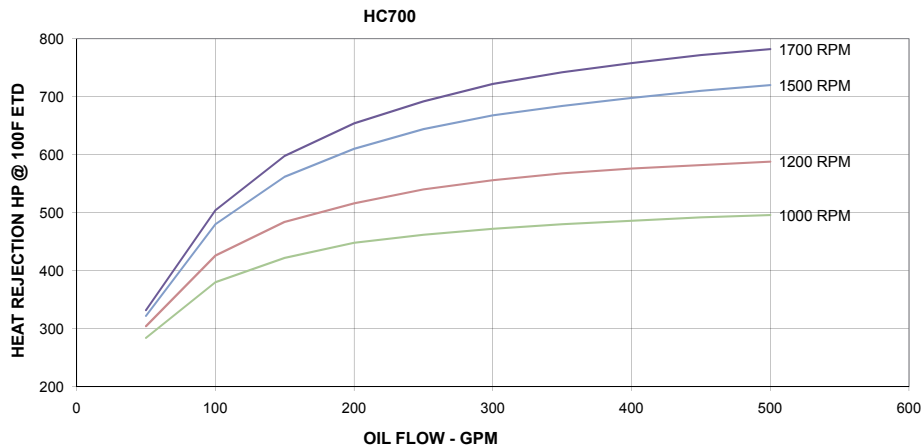

## SIZING/RATINGS BASED ON

- Max Pressure Rating - 250 PSI**
- Max Operating Temp - 250° F**
- Material - Aluminum**
- 100 PSIG Operating Pressure**
- 100° F ETD (Entering Temp Difference)**
- 50 SUS Oil**

## ORDERING INFORMATION

HC700 -

**MOTOR CODE**

**0 = No Motor**

**0195 = 1.95 cu-in Hydraulic Motor**

**AKG Thermal Systems, Inc.**

P.O. Box 189; Mebane, NC 27302-0189; Phone: +1 919-563-48-71; Fax: +1 919-563-49-17

E-Mail: sales@akgts.com; Internet: www.akgts.com