

HC SERIES BYPASS COOLERS

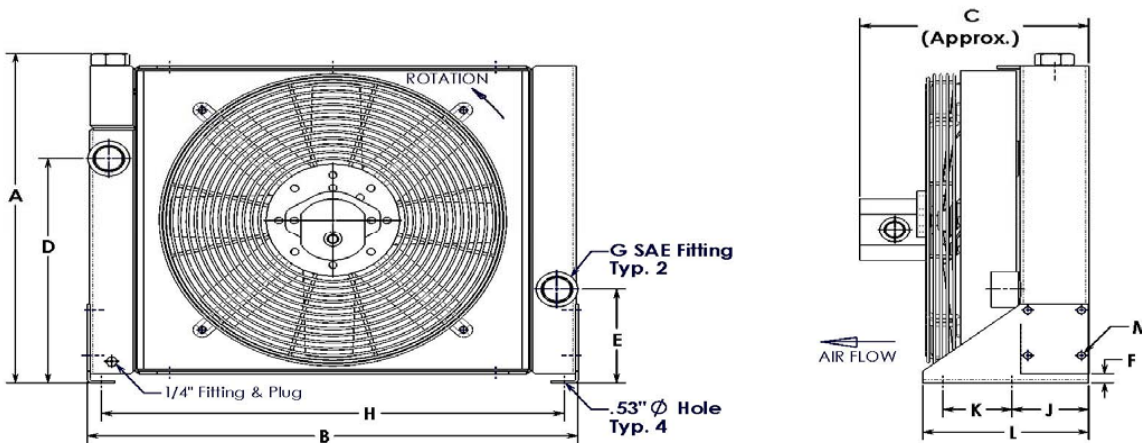

COOLER DIMENSIONS



TECHNICAL DATA

MODEL NUMBER	A	B	C (Approx.)	D	E	F	G	H	J	K	L	M	P	Approx. Weights				
														Net	Shipping			
HC 14	12.83	16.20	10.98	6.61	3.31	0.55	#16 SAE 1 5/16-12 UN-2B	14.72	3.09	3.50	7.38	M8x10 Bolt (4 PL)	#8 SAE 3/4-16 UN-2B	42	47			
HC 26	16.72	20.15	10.98	10.47	3.31	0.55		18.66						62	67			
HC 32	16.97	20.67	12.60	10.12	6.02	0.59	#20 SAE 1 5/8-12 UN-2B	19.45	4.17	3.74	9.02	M10x20 Bolt (8 PL)	#12 SAE 1 1/16-12 UN- 2B	67	77			
HC 48	21.26	26.65	12.09	14.49				25.16						4.17	3.74	9.02	139	177
HC 66	23.11	30.59	12.17	16.39				29.09						5.39	7.87	15.47	165	210
HC 120	28.94	39.53	15.12	19.84	9.92	2.13	2" SAE 4-Bolt FLANGE	37.72	5.39	7.87	15.47	M12x20 Bolt (8 PL)	#12 SAE 1 1/16-12 UN- 2B	242	302			
HC 180	37.48	43.46	17.32	29.52	9.06	2.13		41.65						352	407			
HC 240	39.37	45.33	18.78	31.14	9.04	2.11		43.52						380	447			
HC 300	45.34	51.24	20.94	34.49	11.02	1.40	3" SAE 4-Bolt FLANGE	49.43	7.4	10.39	21.57	3/4 X 1 1/2 Bolt (8 PL)	#16 SAE 1 5/16-12 UN- 2B	532	620			
HC 380	59.76	53.01	20.94	43.62	17.56	2.04		50.35						787	877			

ORDERING INFORMATION

HC SERIES

MODEL SIZE
SELECTED

MOTOR CODE
0 = No Motor
0218 = 0.218 cu-in
0372 = 0.372 cu-in
0050 = 0.50 cu-in
0120 = 1.20 cu-in
0140 = 1.4 cu-in
0195 = 1.95 cu-in

BYPASS DATA
BPNV = BYPASS NO VALVE
BP25 = 25PSI INT BYPASS
BP30 = 30PSI INT BYPASS
BP60 = 60PSI INT BYPASS
BP65 = 65PSI INT BYPASS

CUSTOM FEATURE CODE
R = Reversed Air Flow
AD = SAE to NPT Adaptors
H = Heresite Coating Core
F = Filter

AKG Thermal Systems, Inc.

P.O. Box 189; Mebane, NC 27302-0189; Phone: +1 919-563-48-71; Fax: +1 919-563-49-17

E-Mail: sales@akgts.com; Internet: www.akgts.com